

QUANSER
INNOVATE. EDUCATE.

Universal Power Module

1503,1506,2405,2405-PWM

User Manual

1. Description

The Universal Power Module is a power amplifier that is required to drive each Quanser actuator. The UPM consists of:

- [1] ± 12 Volt Power Supply.
- [4] Analog Sensor Inputs.
- [1] Power Amplified Analog Output (the gain is set by the choice of cable).

The above mentioned ports all provide test points alongside the standard connections to provide complete access to the inherent signals. These test points can be monitored externally if the user wishes (i.e. through an oscilloscope).

2. Module Options

The following is a table of Universal Power Modules available from Quanser:

Power Modules					
Model	Maximum Output Voltage	Maximum continuous Current	Output	Type	Number of Outputs
UPM-15-03	15	3	Linear	Voltage	1
UPM-15-06	15	6	Linear	Voltage	1
UPM-15-03x2	15	3	Linear	Voltage	2
UPM-24-05	24	5	Linear	Voltage	1
UPM-24-15-PWM	24	15	<i>PWM</i>	Current	1

Table 1 Available UPM Options

3. Common UPM Connections

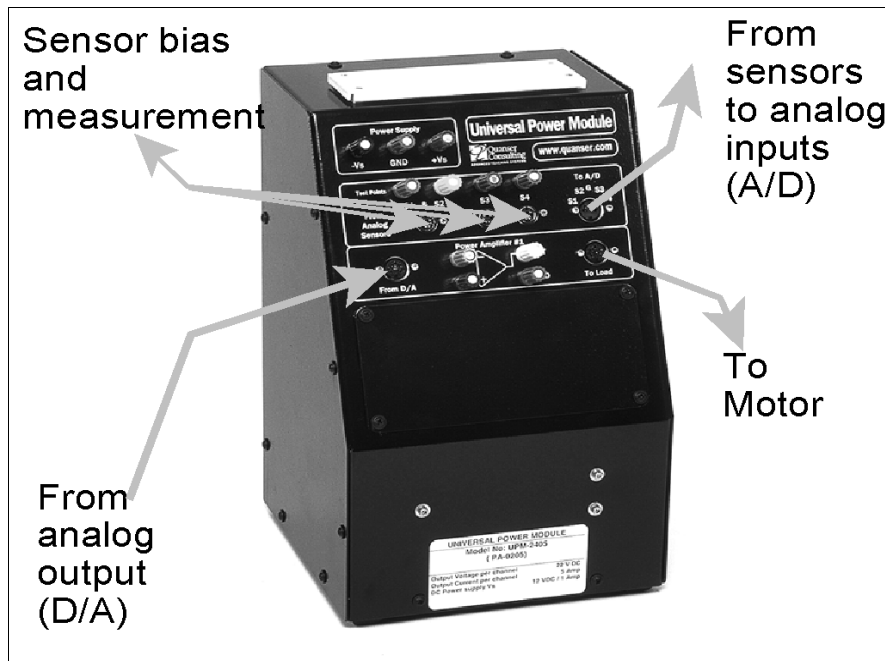

Figure 1 Typical UPM Connections

<i>From...</i>	<i>To...</i>	<i>Cable</i>	<i>Description</i>
D/A output Channel #0	'From D/A' on UPM	RCA to 5-pin DIN	This is your output signal that needs to be amplified.
Sensors	S1,S2,S3,S4 on UPM	6-pin mini DIN	Connect all your analog sensors to the UPM (provides bias).
'To A/D' on UPM	A/D input Channels 0,1,2,3	5-pin DIN to 4 RCA cables	Routes all your sensor inputs to the DAC card
'To Load'	Motor	6-pin DIN to 4-pin DIN	This is the amplified signal used to drive your motor (or actuator).

Table 2 Most Common Configuration of UPM

***Note:** Any Encoder inputs should be connected **DIRECTLY** to the DAC card. **DO NOT** Connect any Encoder signals to the UPM.

4. Linear Power Modules

The following sections describes the majority of the Universal Power Modules available from Quanser. The UPM models that fall into the Linear category are:

- UPM 15-03
- UPM 15-06
- UPM 15-03x2
- UPM 24-05

The **motors** used in Quanser systems are DC motors. They may be either direct drive motors or geared motors. Geared motors have an internal gearbox which can be readily distinguished from the motor itself by examination. The motors are driven by the output of the amplifier (**UPM**). Voltage driven motors are driven using the **UPM-XX-YY** (NOT PWM). With the supplied cables, the circuit achieved is shown in Figure 2 below. The motor connector for motors that use the **UPM-XX-YY** power modules is a 4 pin DIN connector which is connected to the motor as shown.

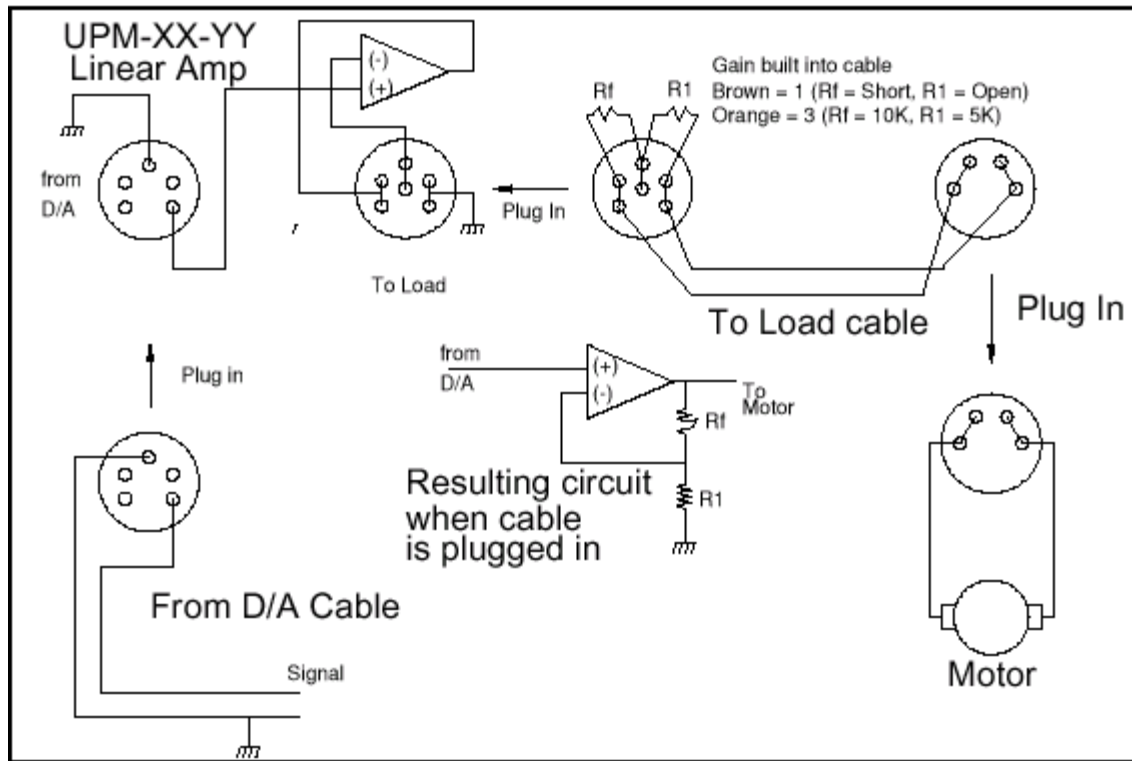

Figure 2 UPM XX-YY Schematic

**Note: Notice the resulting circuit is completed with the supplied cables. These cables are each calibrated to supply a specific gain and are clearly labeled. Always make sure that you are aware of the gain cable being used.*

5. PWM Power Amplifiers

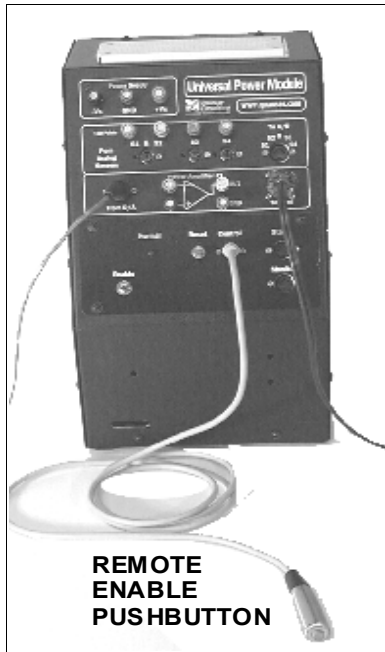

Figure 3 UPM-XX-YY-PWM

Motors that use the *UPM-XX-YY-PWM* have 6 pin connectors. The current gain in the amplifier is factory configured to output $2 \times YY$ amperes at 5 volts. The *output terminals are floating!* **DO NOT ATTACH A GROUND TO EITHER TERMINAL.** Furthermore, the PWM type amplifiers have the control panel shown in Figure 4.

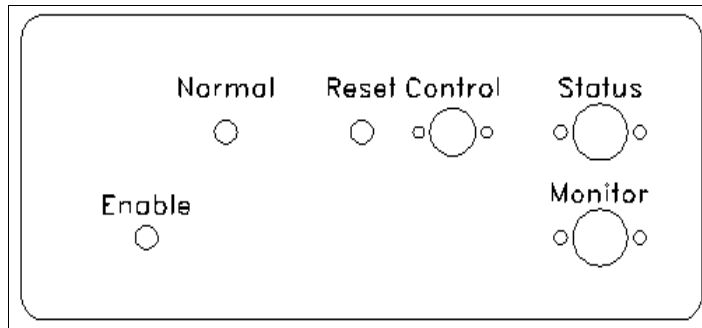

Figure 4 PWM Control Panel

The **Enable** switch along with the **Remote Pushbutton** enable the output of the amplifier. With the switch down or the pushbutton released, no power is delivered to the load. The **Normal** light indicates that the amplifier is enabled. In case of short circuit, the amplifier shuts off automatically and the **Reset** pushbutton must be used to re-initialize it.

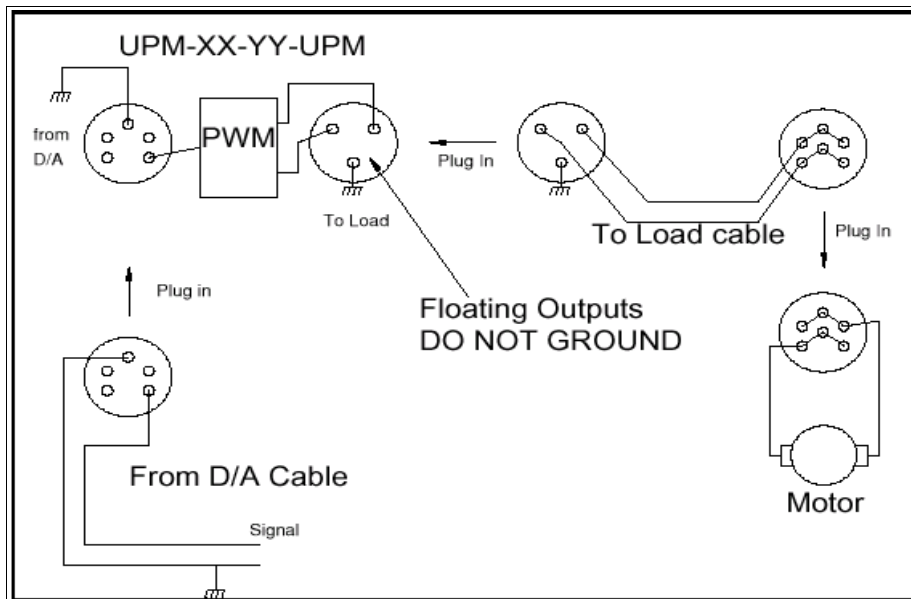

Figure 5 UPM-XX-YY-PWM Schematic when Operating in Normal Mode

The three **Control** signals should be grounded externally. All three enable lines must be tied low for the amplifier to operate normally. Floating any of the control signal results in disabling the amplifier output in one or both directions. The circuit on the left shows how the amplifier is used in normal operation. The **Enable** switch is tied in series with the **Remote** switch, the **Amplifier Enable** line and **Ground**. Both switches must be closed for the amplifier to operate normally. The Left Enable and Right Enable lines are tied low inside the Safety cable. You may use these lines to control the load in various manners.

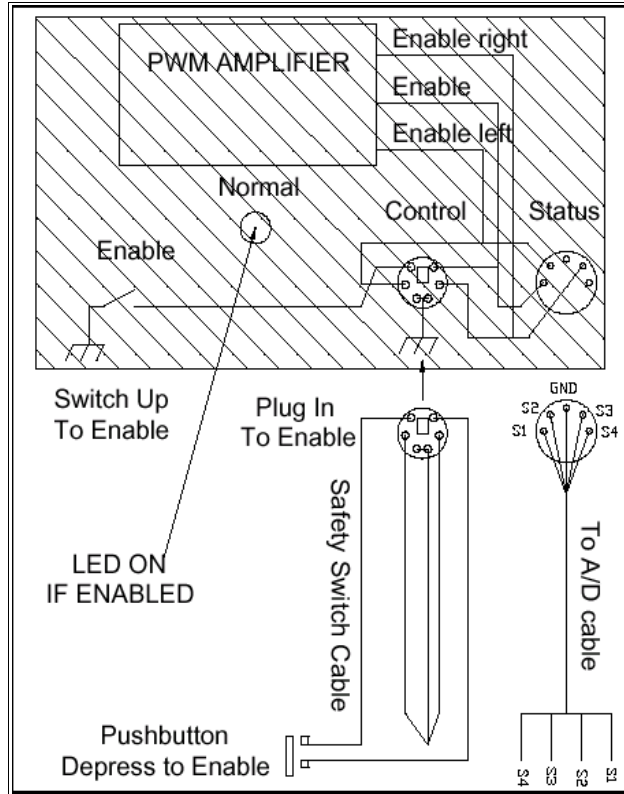

Figure 6 PWM Enable Signal Schematic

The Enable Status of the amplifier may be monitored through the signals available at the **Status** socket. If you use our standard 5 pin Din to 4 RCA cable, then the signals measured are as described in Table 3 below.

Status 5 Pin Din Socket	S1	Enable	S2	Enable Left	S3	Enable Right	S4
	Low = Enabled		Low = Enabled		Low = Enabled		N/A

Table 3 Signals available when connected to the STATUS socket

You may also monitor the amplifier related signals through the **Monitor** Socket. The signals you can monitor are the pre-amplifier voltage, the amplifier voltage and the **Current Monitor** signal which outputs a voltage proportional to the current being supplied. If you use our standard 5 pin Din to 4 RCA cable connected to the **Monitor** socket, the following signals can be measured.

Monitor 5 Pin Din Socket	S1	Pre-Amp	S2	Current Amplifier	S3	Current Monitor	S4
	1 Volt / volt		1 Volt / volt		(YY / 3) Ampere /voltage		N/A

Table 4 Signals available when connected to the MONITOR socket

6. Recommended Power Modules

The following table is a reference to determine which Power Module should be used with each specific Quanser experiment. These following systems have been designed and tested with the specified configuration. Failure to adhere to these suggestions may result in unsatisfactory results and performance.

Actuator	Recommended Power Module
SRV02, SRV02-E	UPM-15-03
IP01,IP02	UPM-15-03
SRV03	UPM-24-15-PWM
Shaker Table Hi G AMD	UPM-24-15-PWM
2DOF Helicopter	Front Motor: UPM-24-05 Back Motor: UPM-15-03
3DOF Helicopter	UPM-12-03 x2
HiWire	UPM-15-03

Table 5 Recommended Power Modules for Quanser Actuators